

Brick HVLS Ceiling Fans – Commercial PMSM Solution

Exciting Innovations

Al-Pc Complex Blade

Two materials compose blade.
Shell by engineering plastic,
Skeleton by aluminum tube
Total weight reduces 40%
No blade resonance.
Energy saving.

Blade Interconnect Grille

A nylon cord interconnects every blade in turn to form a floating ring.
3-5 rings along the radial which tie
All blades build a protection grille to hold any free-fall blade.

Skeleton Interconnect Ring

A cord connects all blade skeletons to form a ring prevent any blade from flyoff

steel ropes tie all immovable parts.

only for outer rotor motor
one steel rope go through the hollow axle of the motor, fixed by a flange plate at bottom,
another rope wraps the roof beam and goes through extension tube, two ropes tie together at the top of the axle.

A complete protection ring from “ head to foot”.

Spec./Model/Param/Config

Items	Detail Descriptions				
Product Model	BRK-LD5-1.1/D**				
BRK-HD5 Series	-/D12	-/D11	-/D10	-/D9	-/D8
Diameters mm	3700,	3300,	3100,	2800,	2500
Max. rpm	90	95	100	110	120
Air Circulating m³/m	8600,	6300,	4700,	3900,	3000
Extend Reach m²	380,	310,	260,	220,	180
Hanging weight kg	80	75	50	48	45
PMSM Motor	0.7 kw / BRK Custom-made			0.4kw	
Power Data	220V/1P, 50-60 Hz				
Control Panel	BRK Custom-made, stepless speed regulation				
Motor Rack + Hub	Blade skeletons directly fixed on upper cover of the motor				
Blade+ related safety advice	5 blades /188mm width, <u>Al-Pc Complex Blade</u> + <u>Blade Interconnect Grille</u>				
Colors	Motor rack: Dark grey, Blade: Light grey				
Motor shell color	Silver or Black				

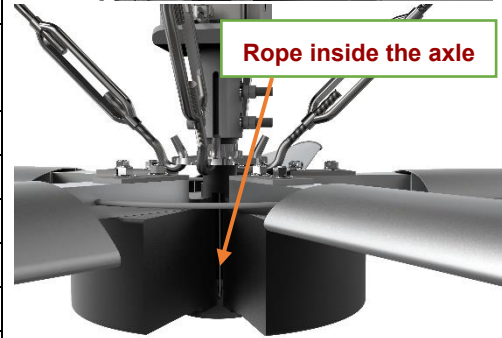
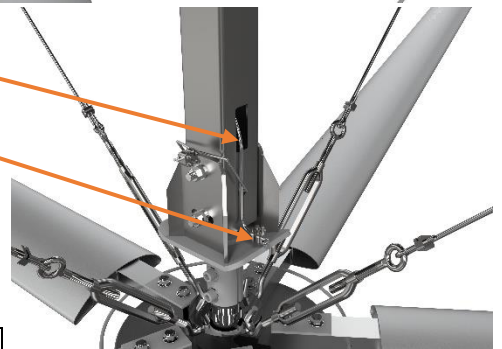
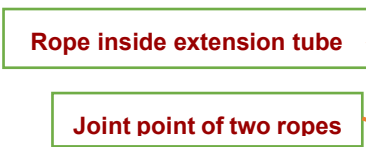
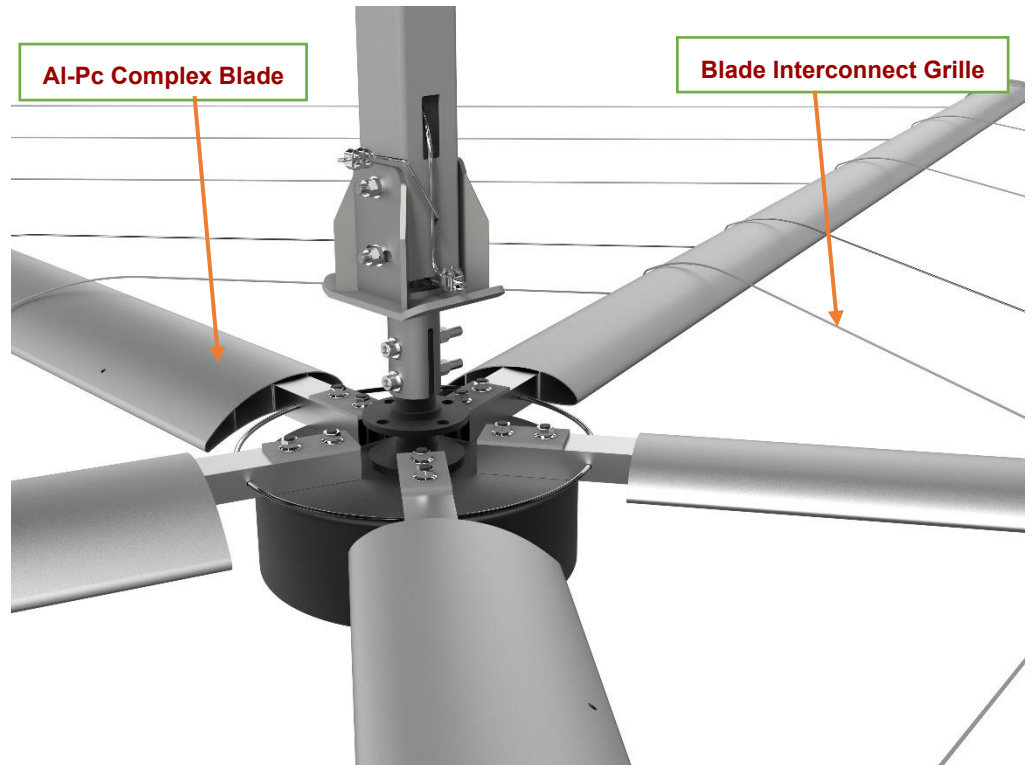

Superiorities of Al-Pc Complex Blade

- Plastic material needs lower melting temperature in extrude process, consume less energy.
- reduce 40% in weight compare to aluminum blade, save driven power, cut down skeleton load and minimize metal fatigue, prolong service life.
- Two materials compose blade, plastic shell and aluminum skeleton, the blade will not resonate. Most of broken blades were caused by metal fatigue at root position.
- No resonance plus lightweight will generate higher rpm, faster ground airflow and larger extend reach by equivalent power.
- Easy clean, no water stain left after water clean.
- blade color optional for long term buyers or large order.
- Blade Interconnect Grille will prevent blade from free fall, which substantially upgrade the Safety and reliability criteria in industry.
- Nylon cord of Grille is light and easy to knit, decrease the load and Installation time.

Reliability and quality of Al-Pc complex Blade

- Main ingredient of blade contour is polycarbonate (PC), it is an engineering plastic of high performance-price ratio.
- PC is widely applied in mechanical and optics industry since its outstanding features in mechanical, heat-resisting, and anti-aging. such as glass window on aircraft, gear and crank axle on machine etc.
- Service life of PC is over ten years in interior application.
- Skeleton undertake strength and rigidity of blade on radial. it made of extrude aluminum, exactly same with aluminum blade. Compared with the latter, Curve down phenomenon on blade will ease in years application as skeleton bear less load, cantilever load also decline. Working condition of skeleton is better than aluminum blade.
- The blade strength of transverse section partly be undertaken by PC, 4 vertical stiffeners in inner cavity are set to ensure the contour no twisted, deformed or broken.
- Durability and reliability of Al-Pc Complex blade is superior to aluminum blade.

Brief Introduction to Brick

- First branded OEM manufacturer in industry, dedicated to R&D and manufacturing.
- Distributor and agent focus on site service, backed by Brick.
- Brick mission is to promote new technology and products, upgrade safety and reliability criteria substantially.
- Technologies such as Al-Pc Complex Blade + Blade Interconnect Grille + bilayer Motor rack + Skeleton Interconnect Ring for HVLS Ceiling Fans, and Segment Structure + Ladder Shaped Flank Grille for portable fans etc. they are all originally and initially invented by Brick, which innovatively improve or substantially resolve the existing problems, related to safety and reliability.
- Initially launch Concentrated or Broad Airflow Blade on portable and Pivot Fans
- Initially launch Dock Fans of jet stream for long trailer, first supplier in industry to focus on improvement of muggy environment inside container.
- All those innovative technologies have applied patents.

Distributor Information

Brick (GD) Machinery Technology Co., Ltd.
Block #43, Zhong Jin Run Industrial Park, Yue-Gui Cooperation Zone, Ping Feng,
Feng Kai County, Zhao Qin City, Guangdong, PRC.
Cell: (0) 157 6715 8231
E-mail: sales@Brick-Air.com
Web-site: www.Brick-Air.com

Other innovative products



HVLS Fans by Gear motor



Portable Fans



HVLS Fans-PMSM Motor

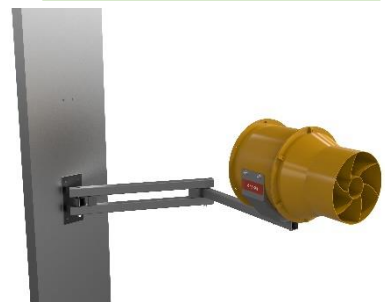

Dock Fans



Pivot Fans